



GenWriter

BM-GenWriter3.0-V1.2



Brief Manual of GenWriter V3.0 (S1000 / G1000)

V1.2

March 2008

- u CORERIVER Semiconductor reserves the right to make corrections, modifications, enhancements, improvements, and other changes to its products and services at any time.
- u CORERIVER shall give customers at least a three month advance notice of intended discontinuation of a product or a service through its homepage.
- u Customers should obtain the latest relevant information before placing orders and should verify that such information is current and complete.
- u The CORERIVER products listed in this document are intended for usage in general electronics applications. These CORERIVER products are neither intended nor warranted for usage in equipment that requires extraordinarily high quality and/or reliability or a malfunction or failure of which may cause loss of human life or bodily injury.



www.coreriver.com (E-mail : tech@coreriver.com)

Contents

[PART I : Introduction]

- u Overview

- u Features

[PART II : GenWriter H/W Equipment]

- u Single Writer (S1000)

- u Gang Writer (G1000)

- u Configuration

[PART III : How to Use]

- u How to Download the HEX File to S1000

- u Programming MCU with GenWriter

[PART IV : GenWriter Manager]

- u Program & Toolbar

[Appendix : LCD Message]

- u Information Message

- u Error Message

PART I : Introduction

- u Overview

- u Features

1. Overview

- u GenWriter V3.0 is CORERIVER's exclusive romwriter.
- u It supports all CORERIVER MCU Families.
 - ü GenWriter V3.0 S1000 is single romwriter of stand alone mode.
 - ü GenWriter V3.0 G1000 is 4-Gang romwriter.

2. Features

- u Supply Voltage : 12V DC (3.0A)
- u Display
 - ü LCD Display : Device, Hex Name, Success and Fail Message Display
 - ü LED Display : Run and Fail Display
- u Supported File Format
 - ü Intel HEX, ASCII HEX
- u Adapter list (Option)
 - ü 28SOIC/44PLCC for MiDAS1.0 Family
 - ü 8/14/16/20 SOIC for MiDAS1.1 Family
 - ü 44MQ/64LQ/64TQ/100TQ for MiDAS2.0 Family
 - ü 28SOP/32LQ for MiDAS2.1 Family
 - ü 20SPDIP/20SOIC/20MLF/16SPDIP/16SOIC/8SP DIP/8SOIC for MiDAS2.2 Family
 - ü 32MLF/44PQFP/44LQFP for MiDAS3.0 Family
 - ü 8SOP/20SOP/24SOP for ATOM1.0 Family
 - ü 32-LQ/32-MLF for RoboCore1.0 Family
 - ü 20QFN/20SOIC/8SOIC for TouchCore1.0 Family
- u Tool Configuration
 - ü Single : GenWriterV3.0 S1000
 - ü 4Gang : GenWriterV3.0 G1000
- u Supported Device :
 - ü MiDAS1.0
 - ü MiDAS1.1
 - ü MiDAS2.0
 - ü MiDAS2.1
 - ü MiDAS2.2
 - ü MiDAS3.0
 - ü ATOM1.0
 - ü RoboCore1.0
 - ü TouchCore1.0

PART II : GenWriter H/W Equipment

- u Single Writer (S1000)
- u Gang Writer (G1000)
- u Configuration

1. Single Writer (S1000)

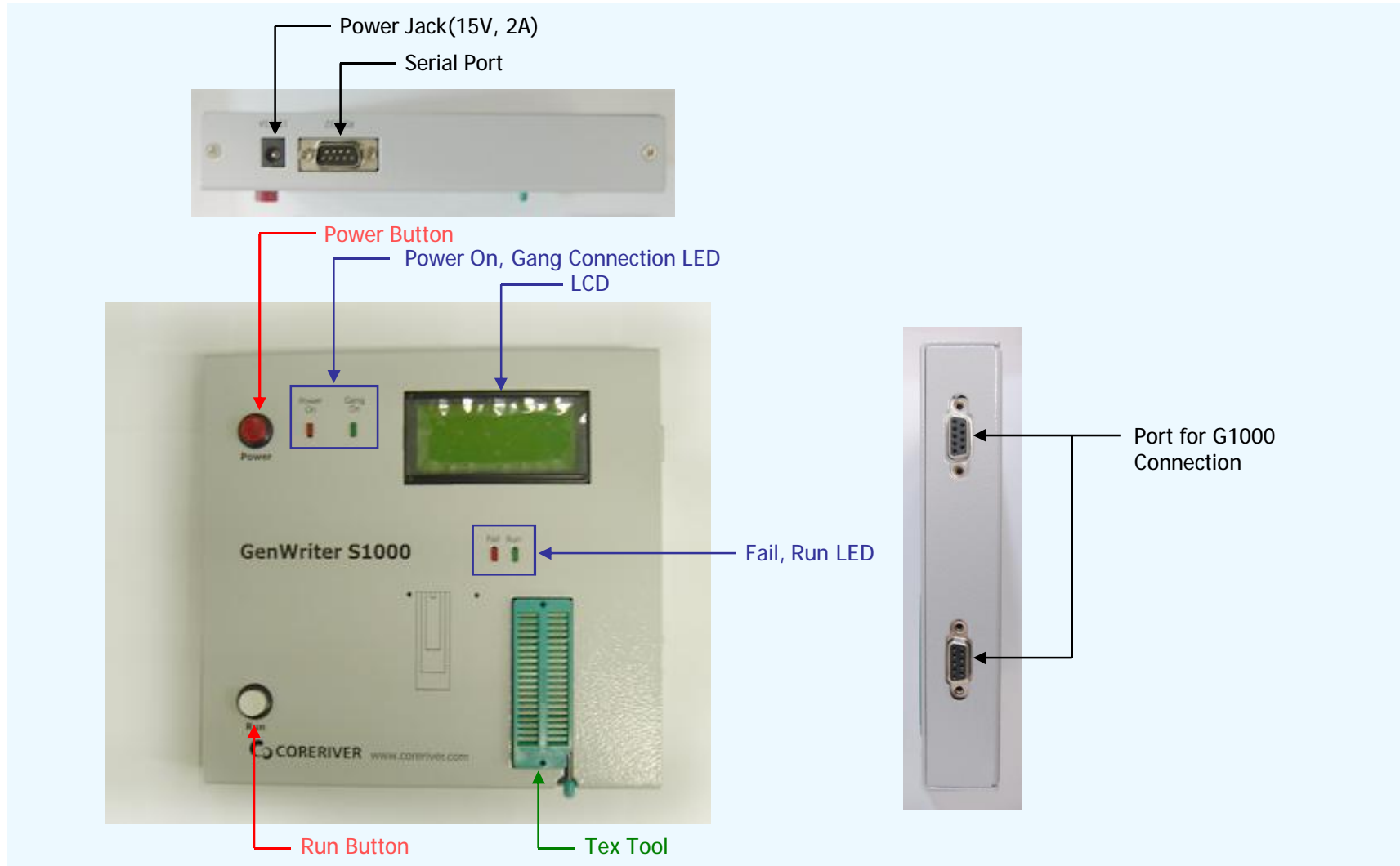

2. Gang Writer (G1000)

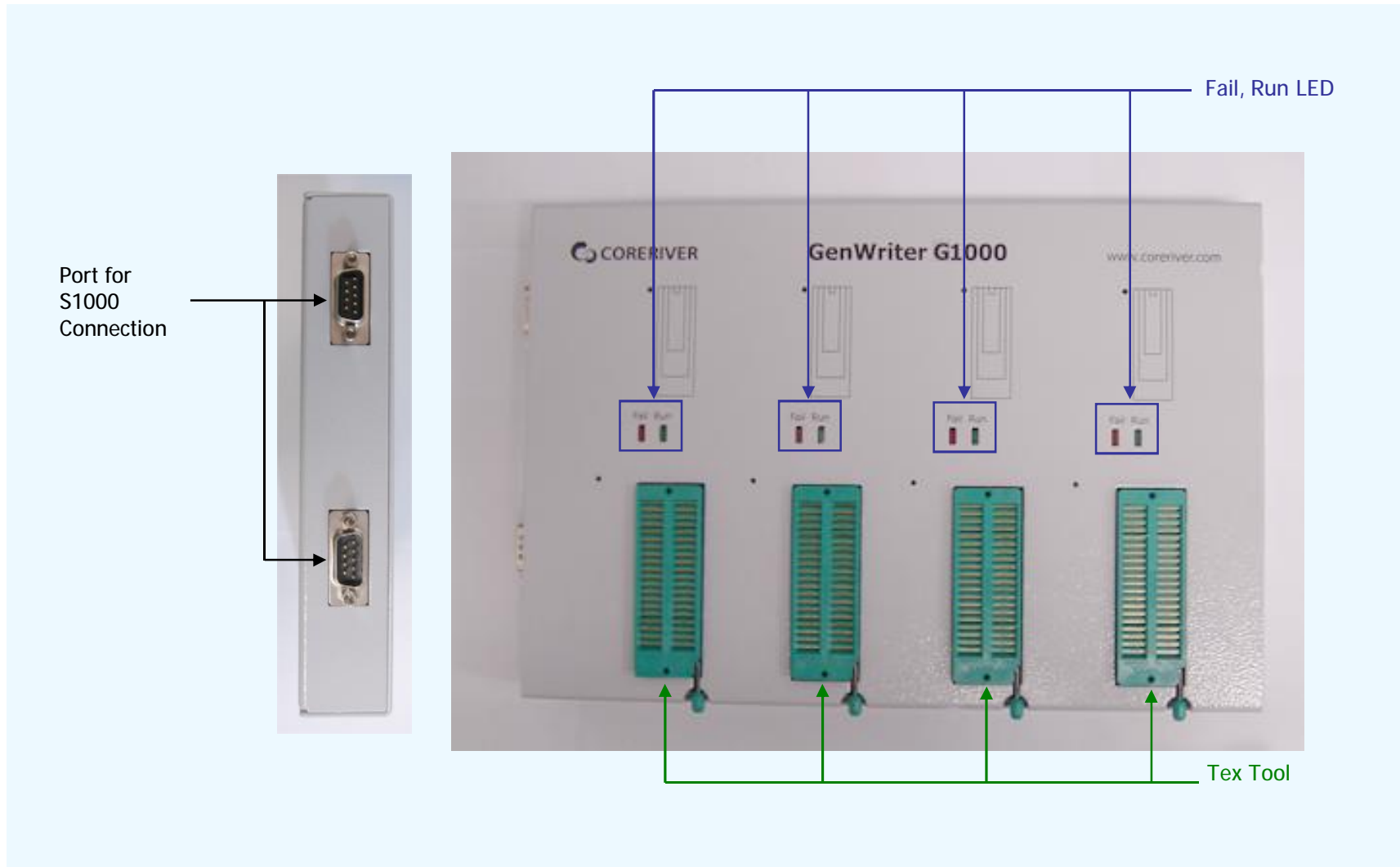

3. Configuration

- Configuration for GenWriter Programming Environment.

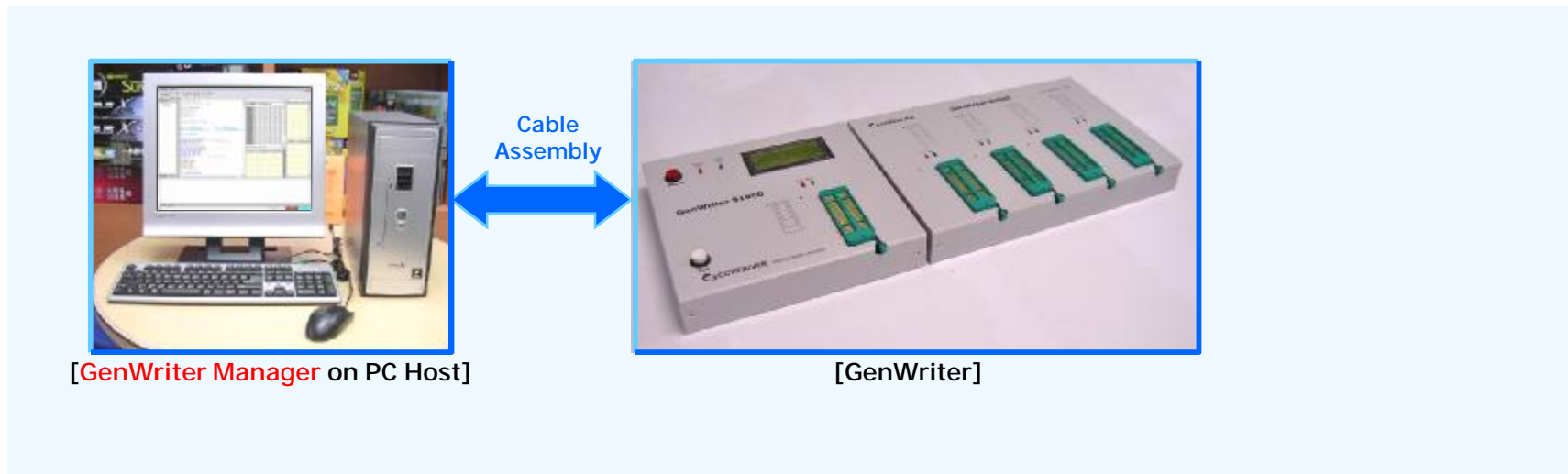

- Accessories.



PART III : How to Use

- u How to Download the HEX File to S1000
- u Programming MCU with GenWriter

1. How to Download the HEX File to S1000

1. Set up the S1000 and PC.
 - 1) Install GenWriter Manager in your PC.



[GenWriter Manager on PC Host]



[S1000]

2. Set up accessories.
 - 1) Serial cable.
 - 2) Power adaptor. (15V, 2A)

Serial Cable



Power Adaptor
(SMPS, 15V, 2A)



1. How to Download the HEX File to S1000

3. Connect the S1000 to PC with serial cable.
 - 1) Check whether power of the S1000 is **OFF**.
4. Power on the S1000.

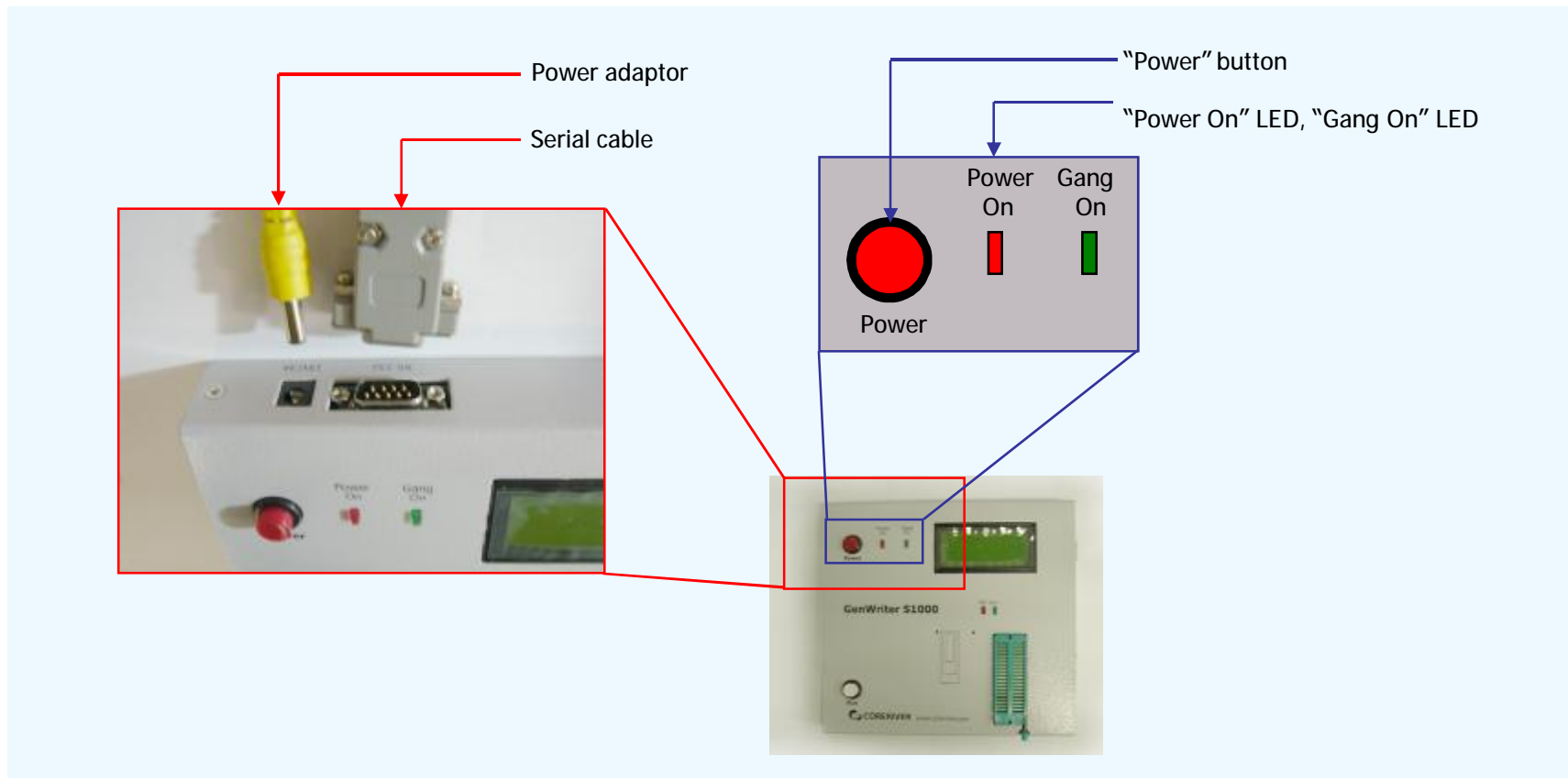

1. How to Download the HEX File to S1000

5. Run the GenWriter Manager. (GenWriter_Manager.exe)

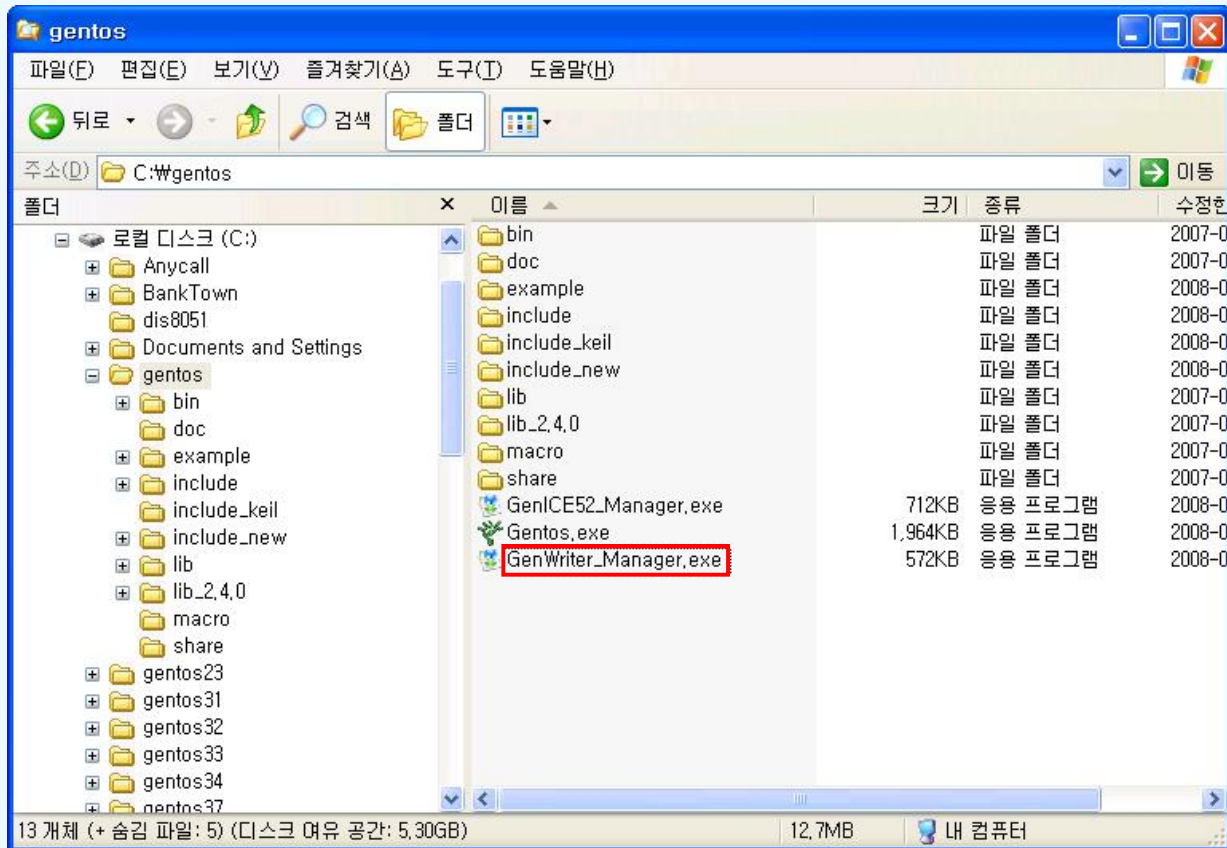

1. How to Download the HEX File to S1000

6. Set "serial", "device".
 - 1) Serial = COM1, 57600 (baudrate)
 - 2) device = Target MCU type
7. Click "Open" button for open the HEX file.

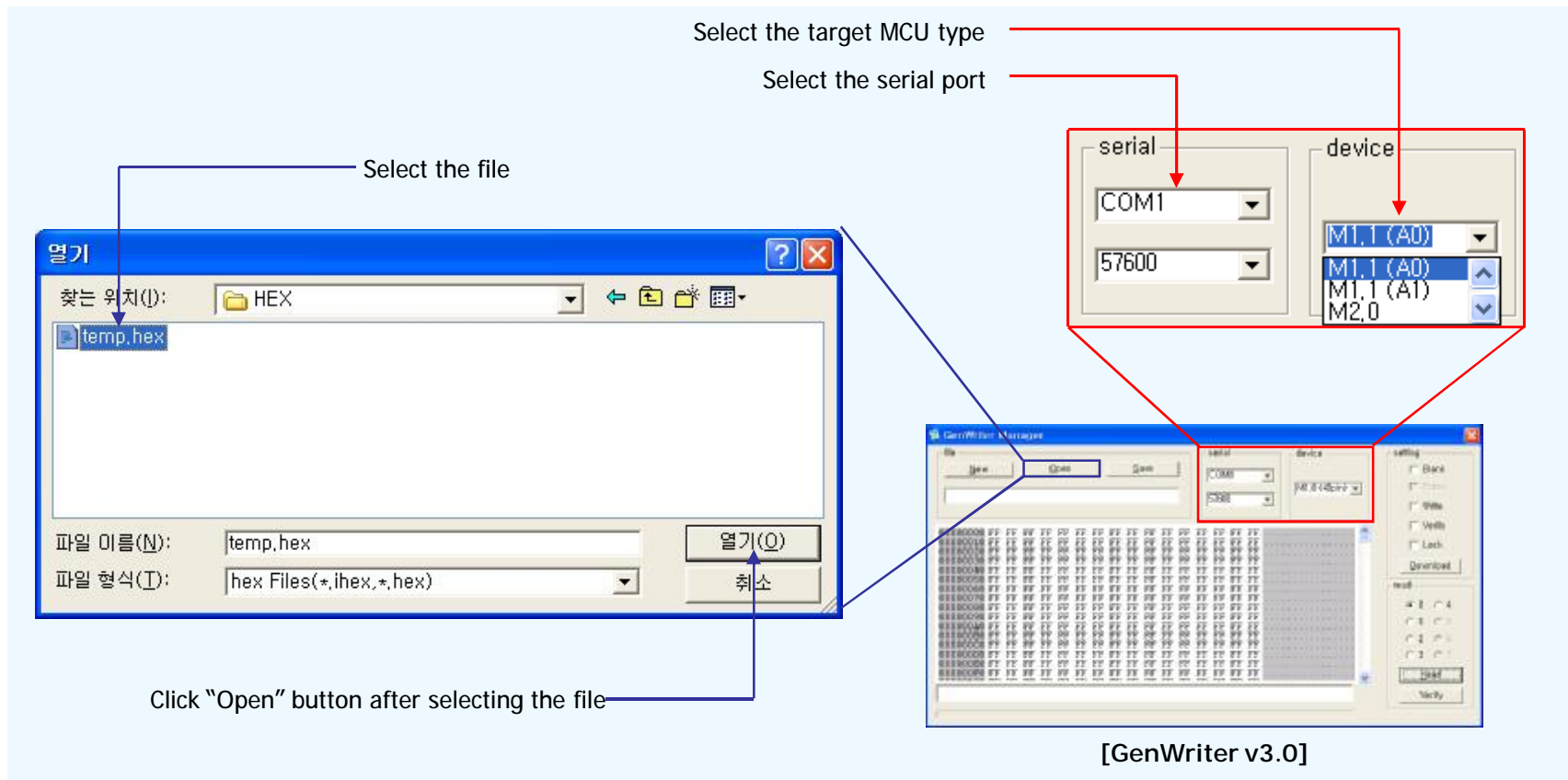

1. How to Download the Hex File to S1000

8. Configure "setting" command. (Blank, Erase, Write, Verify and Lock)

The image shows the GenWriter Manager software interface. A 'setting' dialog box is open, containing the following options:

- Blank
- Erase
- Write
- Verify
- Lock
-

Arrows point from the dialog options to their descriptions:

- Blank** : Check if the MCU ROM is blank status
- Erase** : Erase all data in the MCU ROM (Flash ROM type only)
- Write** : Program the MCU ROM using the HEX code in the Buffer
- Verify** : Verify between the MCU ROM Code and the HEX Code in the Buffer
- Lock** : Check if the MCU ROM is locked
- Download** : Download the "setting" command and the HEX Code

The main GenWriter Manager window shows a hex editor with memory addresses from 00000000 to 000000E0. A progress bar is visible at the bottom of the hex editor area, highlighted with a green box. An arrow points to this progress bar with the text: "See the status for checking the progression."

9. Click the "Download" button for download the "setting" command and the HEX Code.

1. How to Download the Hex File to S1000

10. Check result.

The screenshot displays the GenWriter Manager interface. The main window title is "GenWriter Manager - C:\WHEXWm11_test_full.hex". The interface includes a "file" section with "New", "Open", and "Save" buttons, and a text field containing "m11_test_full.hex - (checksum : 0xE800)". The "serial" section has a dropdown menu set to "COM1" and a text field with "57600". The "device" section has a dropdown menu set to "M1.0 (40pin)". The "setting" section on the right contains checkboxes for "Blank", "Erase", "Write", "Verify", and "Lock", along with a "Download" button. Below these are "read" controls with radio buttons for "0", "1", "2", "3", "4", "5", "6", and "7", and "Read" and "Verify" buttons. The main display area shows a hex dump with columns for address (00000000 to 000000FF), hex data, and ASCII characters. A red arrow labeled "File name (checksum)" points to the file name field. Another red arrow labeled "Start" points to the command line area containing "\$AS_ffff0m11_test_full.hex#F4". Below the main window, a status bar shows "Auto Result Good!" with a progress bar, and a message box displays "Data transfered & Cheksum[0xf800] OK!".

2. Programming MCU with GenWriter

1. Set up the GenWriter and MCU.



[GenWriter]

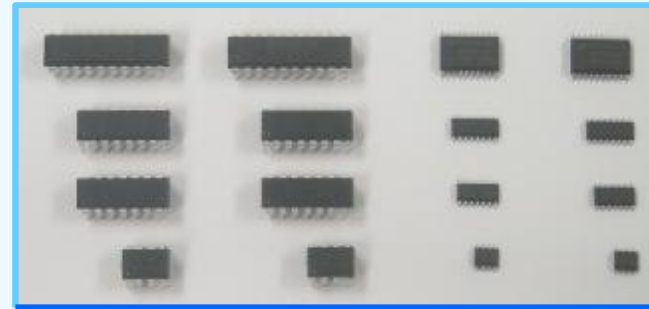

[MiDAS 1.1 Family]

2. Set up accessories.

- 1) Power adaptor (15V, 2A)
- 2) Socket

Power Adaptor
(SMPS, 15V, 2Ah)



Socket



2. Programming MCU with GenWriter

3. Combine the S1000 and the G1000.
 - 1) It is possible for S1000 to program 1 device.
 - 2) It is possible for G1000 to program 4 device.

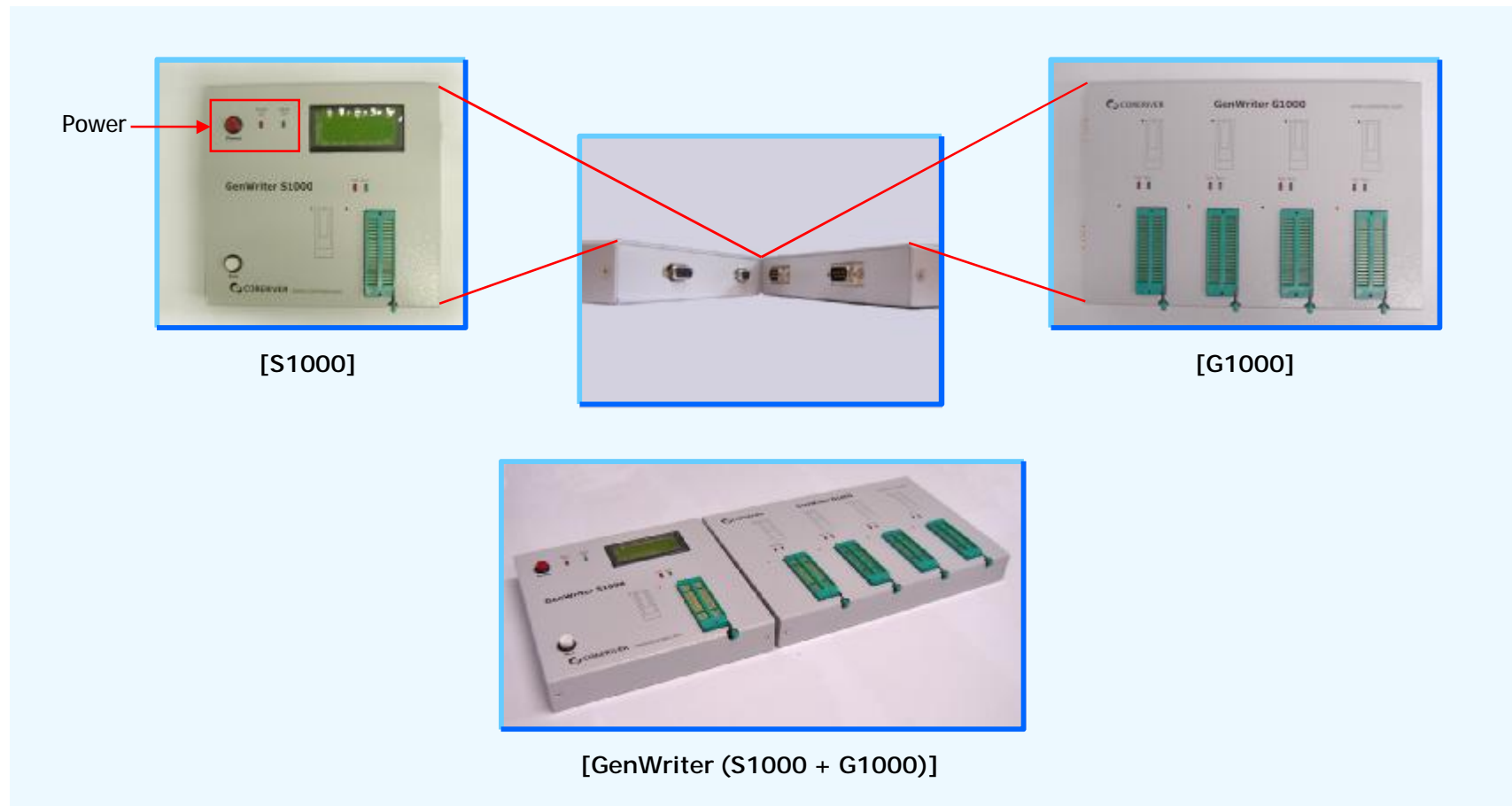

2. Programming MCU with GenWriter

4. Combine the GenWriter and the socket.
 - 1) Select the socket adaptable to the target MCU.



1. Raise the lever

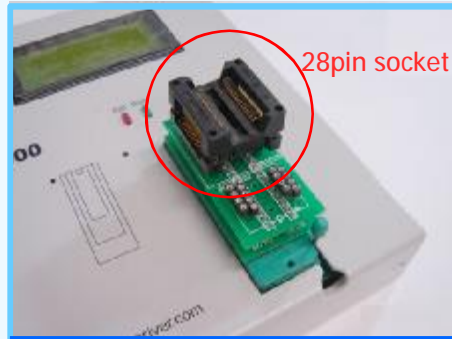

2. Combine the socket

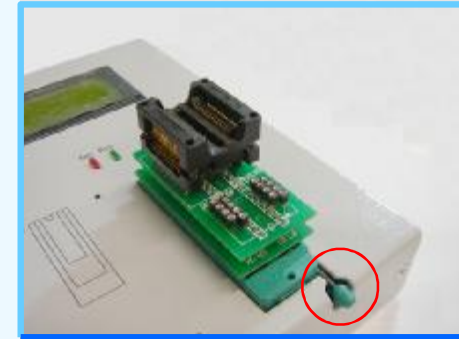

3. Get down the lever



[GenWriter combined with the socket]

2. Programming MCU with GenWriter

5. Fix MCU in the socket.
6. Power on the S1000.
 - 1) Check "Power On" LED.

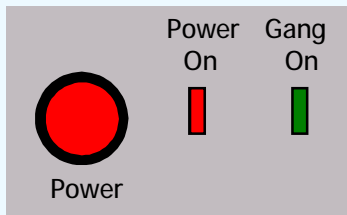

7. Check LCD. (Single mode/Gang mode, target MCU, File, Command)

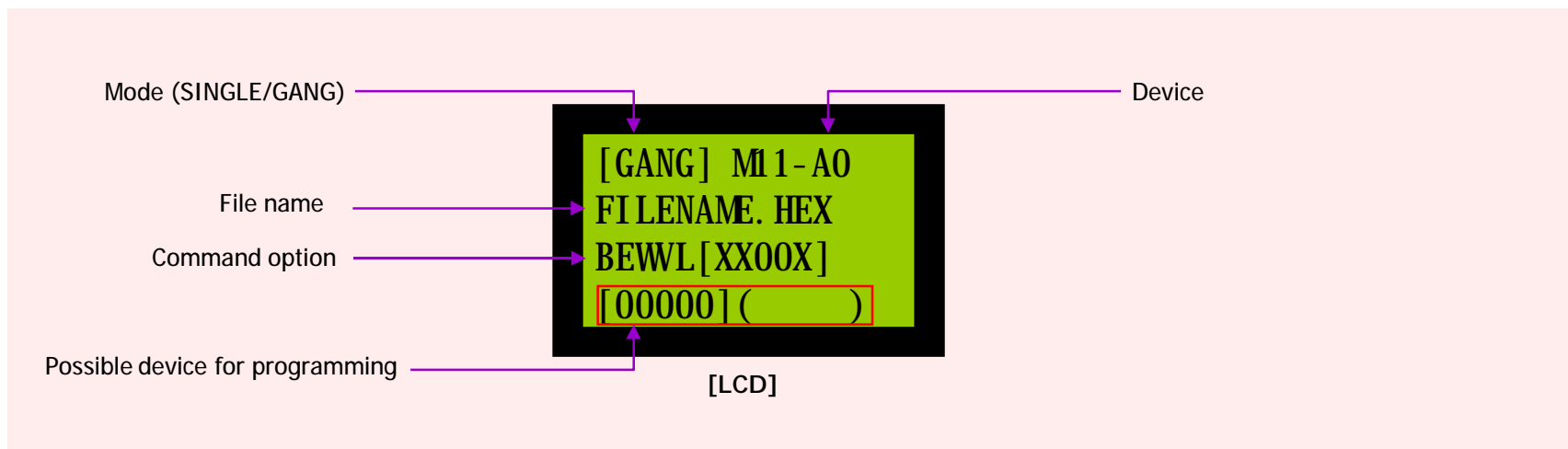

2. Programming MCU with GenWriter

10. Remove MCU after complete.

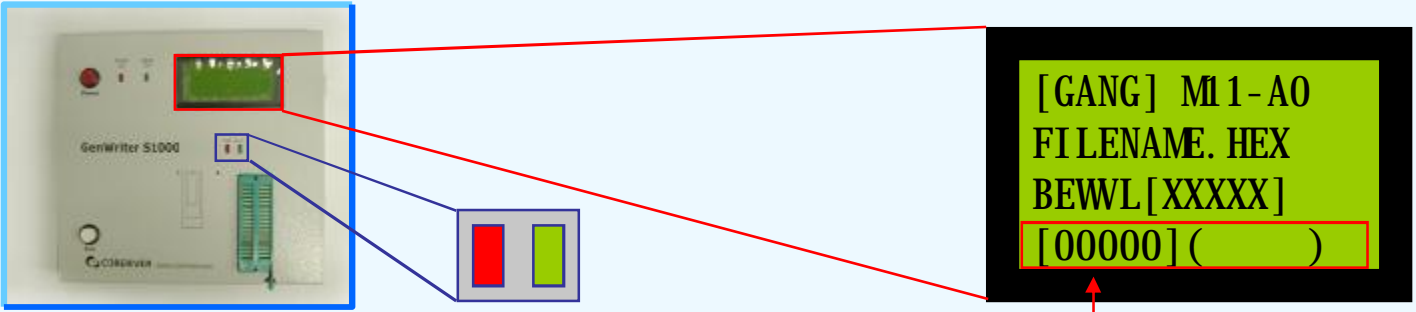

The diagram shows the GenWriter S1000 device with a red box around the LCD screen and a blue box around the LED indicators. A legend below the device explains the LED status: Success (All LEDs Off) and Fail (Red LED On, Green LED Off). A callout box shows the LCD display with the text: [GANG] M1-A0, FILENAME. HEX, BEWL [XXXXX], and [00000] (). A red arrow points from the '0' in the last line to a note: "0" is success message (In other case, Refer to next Slide 27).

[S1000]

Success : All LED Off
Fail : Red LED On, Green LED Off

[LCD]

"0" is success message
(In other case, Refer to next Slide 27)

PART IV : GenWriter Manager

u Program & Toolbar

1. Program & Toolbar

The screenshot shows the GenWriter Manager software interface. The window title is "GenWriter Manager". The interface includes a file menu with "New", "Open", and "Save" buttons. Below the menu is a text input field for the file name and checksum value. The "serial" section has dropdowns for "COM1" and "57600". The "device" section has a dropdown for "M1.0 (40pin)". The "setting" section has checkboxes for "Blank", "Erase", "Write", "Verify", and "Lock", along with a "Download" button. The "read" section has radio buttons for "0", "1", "2", "3", "4", "5", "6", and "7", along with "Head" and "Verify" buttons. The main area is a grid of data, with the first column containing addresses from 00000000 to 000000F0 and the rest containing hexadecimal values (FF FF FF FF). Annotations with arrows point to various parts of the interface:

- Title : Version information
- Initialize the buffer
- Load the HEX file(*.ihex; *.hex) to the buffer
- Serial port setting
- Set Device
- Setting : Refer to next Slide 15.
- Read MCU
- Verify check
- See the status for checking the progression.
- Check or modify the buffer's data being downloaded to the MCU ROM
- File name & checksum value

Appendix : LCD Message

- u Information Message

- u Error Message

1. Information Message

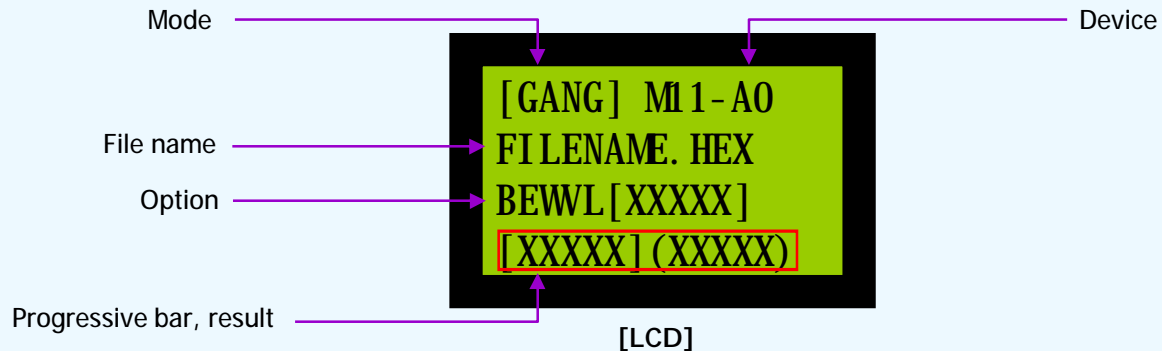

└ MODE

- SINGLE : Single Writer Mode
- GANG : 5 Gang Writer Mode

└ DEVICE : Type of Target MCU

- ※ [note] Please, check the type of the target MCU whether it is consistent with DEVICE to prevent the target MCU from being damaged

└ FILE NAME

- Current downloaded HEX file
- If not downloaded, 'NO FILE' message is displayed.

└ OPTION : Current configured option (Blank, Erase, Write, Verify, Lock), Selected : O Not selected : X

└ RESULT : Success message is "O", in other case, Refer to next Slide 27.

2. Error Message

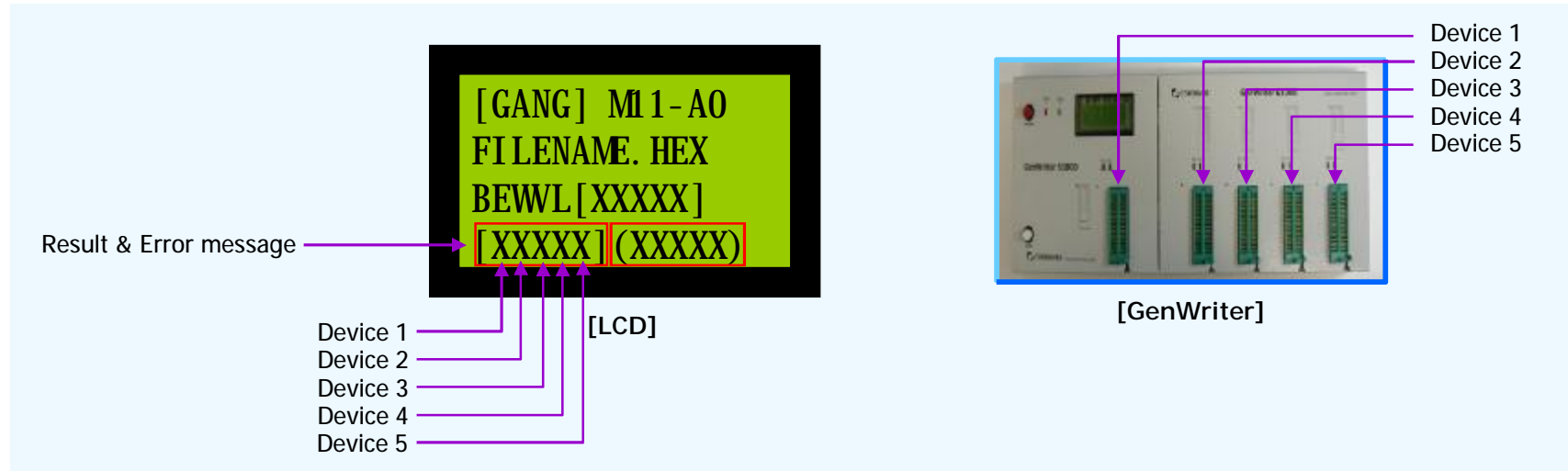

1. Master – Error message

- 1) [X] – Start fail : there is nothing in socket, or device has a bad connection.
- 2) [S] – Check Signature fail : it fails to read device-code.
- 3) [C] – Check Lock fail : device was locked.
- 4) [B] – Check Blank fail : device is not blank.
- 5) [P] – Program fail : it fails to write.
- 6) [R] – Read fail : it fails to read ROM code.
- 7) [V] – Verify fail : device's ROM has not the same code as buffer has.
- 8) [L] – Lock fail : it fails to lock device.